

交流风机的型号说明

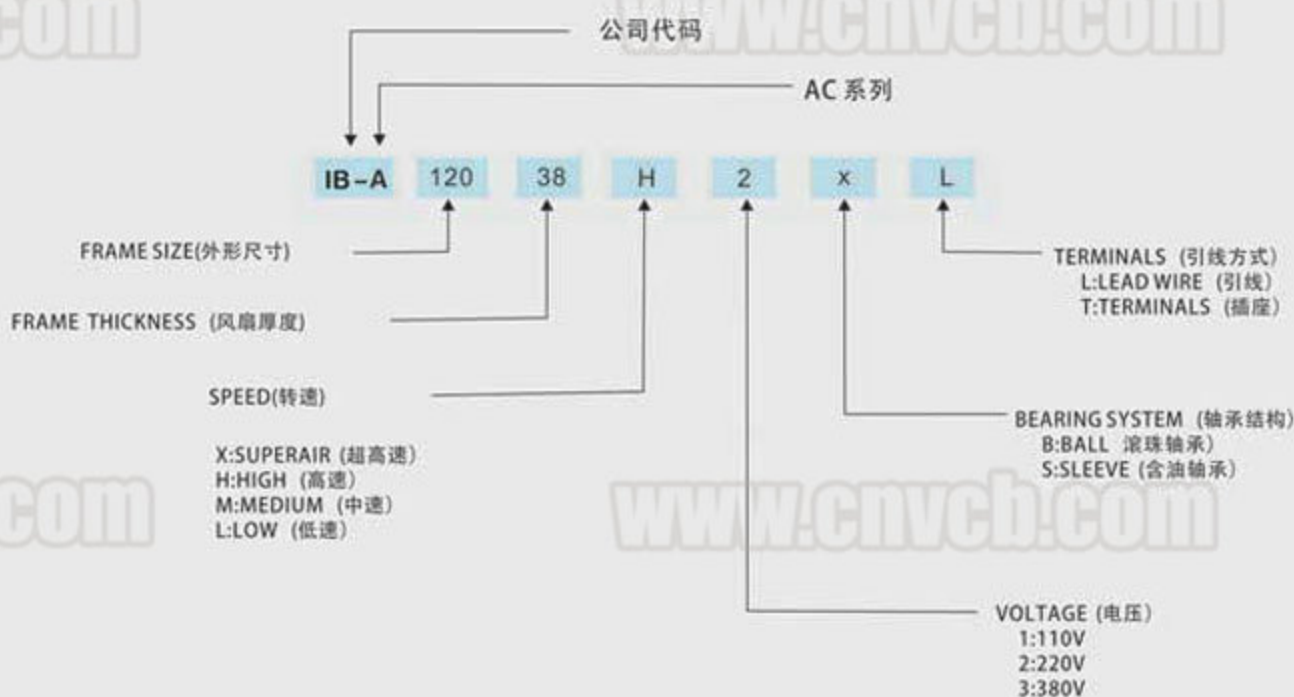

交流风机的内部结构

马达：罩极马达结构
框架：黑烤漆铝合金压铸防腐、防湿结构
风叶：注塑一次成型,PBT+30%玻纤+VO级阻燃剂
轴承：高精度、长寿命进口滚珠轴承;低噪音含油轴承
绝缘：漆包线采用B级绝缘,耐温120摄氏度
绝缘电阻：500兆欧以上
耐电压：漏电流0.5mA,耐电压1800V/min

运行温度：-10摄氏度到+70摄氏度
储存温度：-40摄氏度到+70摄氏度
运行电压：115V(电压范围为:85V-125V)
220V(电压范围为:185V-245V)
工作寿命:滚珠轴承 含油轴承 环境温度
50000小时 30000小时 25℃

AC 系列 IB-A8025



80x80x25mm

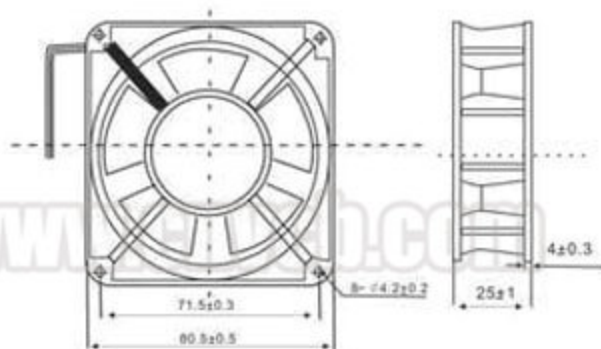

型号	电压	频率	电流	功率	轴承	转速	风量	风压	噪声	耐压
Model	Volt (VAC)	Frequency Hz	Current (AMP)	Power	Bearing system:x	Speed (RPM)	Air Flow (CFM)	Static Pressure	Noise (dBA)	Resist strength
IB-A8025HSL(T)	110/120	50/60	0.12/0.11	15/13	S	2300/2500	20/25	0.12/0.18	30/35	1800v/min
IB-A8025HBL(T)	110/120	50/60	0.12/0.11	15/13	B	2400/2600	23/28	0.13/0.19	32/37	1800v/min
IB-A8025HSL(T)	220/240	50/60	0.09/0.07	15/13	S	2300/2500	20/25	0.12/0.18	30/35	1800v/min
IB-A8025HBL(T)	220/240	50/60	0.09/0.07	15/13	B	2400/2600	23/28	0.13/0.19	32/37	1800v/min
IB-A8025HSL(T)	380	50/60	0.05/0.04	15/13	S	2300/2500	20/25	0.12/0.18	30/35	1800v/min
IB-A8025HBL(T)	380	50/60	0.05/0.04	15/13	B	2400/2600	23/28	0.13/0.19	32/37	1800v/min

AC 系列 IB-A8038



80x80x38mm

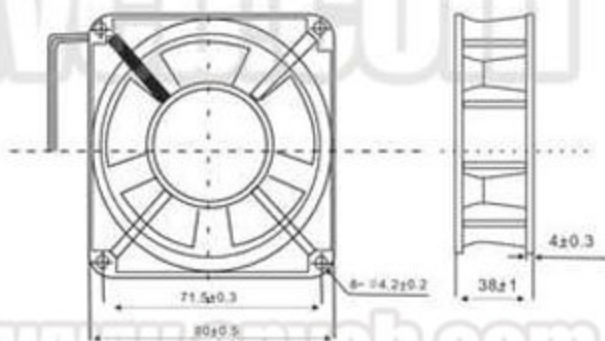

型号	电压	频率	电流	功率	轴承	转速	风量	风压	噪声	耐压
Model	Volt (VAC)	Frequency Hz	Current (AMP)	Power	Bearing system:x	Speed (RPM)	Air Flow (CFM)	Static Pressure	Noise (dBA)	Resist strength
IB-A8038HSL(T)	110/120	50/60	0.12/0.11	15/13	S	2300/2750	23/30	0.12/0.18	31/35	1800v/min
IB-A8038HBL(T)	110/120	50/60	0.12/0.11	15/13	B	2400/2850	24/31	0.13/0.19	32/37	1800v/min
IB-A8038HSL(T)	220/240	50/60	0.10/0.09	15/13	S	2300/2750	23/30	0.12/0.18	31/35	1800v/min
IB-A8038HBL(T)	220/240	50/60	0.10/0.09	15/13	B	2400/2850	24/31	0.13/0.19	32/37	1800v/min
IB-A8038HSL(T)	380	50/60	0.05/0.04	15/13	S	2300/2750	23/30	0.12/0.18	31/35	1800v/min
IB-A8038HBL(T)	380	50/60	0.05/0.04	15/13	B	2400/2850	24/31	0.13/0.19	32/37	1800v/min

AC 系列 IB-A9225



92x92x25mm

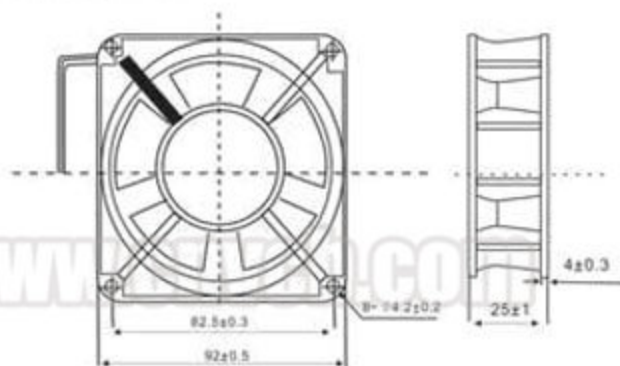

型号	电压	频率	电流	功率	轴承	转速	风量	风压	噪声	耐压
Model	Volt (VAC)	Frequency Hz	Current (AMP)	Power	Bearing system:x	Speed (RPM)	Air Flow (CFM)	Static Pressure	Noise (dBA)	Resist strength
IB-A9225HSL(T)	110/120	50/60	0.12/0.11	15/13	S	2300/2800	28/34	0.11/0.15	34/37	1800v/min
IB-A9225HBL(T)	110/120	50/60	0.12/0.11	15/13	B	2400/2900	30/35	0.13/0.18	35/38	1800v/min
IB-A9225HSL(T)	220/240	50/60	0.09/0.08	15/13	S	2300/2800	28/34	0.11/0.15	34/37	1800v/min
IB-A9225HBL(T)	220/240	50/60	0.09/0.08	15/13	B	2400/2900	30/35	0.13/0.18	35/38	1800v/min
IB-A9225HSL(T)	380	50/60	0.05/0.04	15/13	S	2300/2800	28/34	0.11/0.15	34/37	1800v/min
IB-A9225HBL(T)	380	50/60	0.05/0.04	15/13	B	2400/2900	30/35	0.13/0.18	35/38	1800v/min

AC 系列 IB-A11025



110x110x25mm

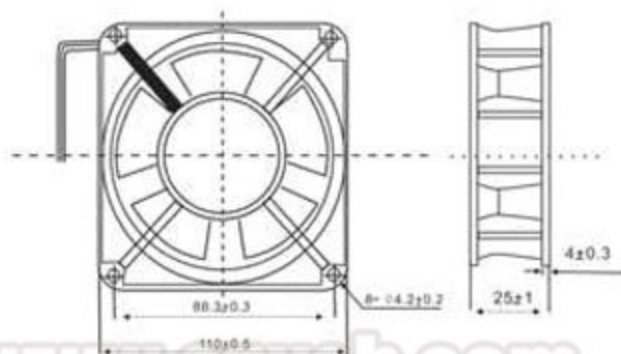

型号	电压	频率	电流	功率	轴承	转速	风量	风压	噪声	耐压
Model	Volt (VAC)	Frequency Hz	Current (AMP)	Power	Bearing system:x	Speed (RPM)	Air Flow (CFM)	Static Pressure	Noise (dBA)	Resist strength
IB-A11025HSL(T)	110/120	50/60	0.12/0.11	18/15	S	2160/2400	42/48	0.10/0.11	38/41	1800v/min
IB-A11025HBL(T)	110/120	50/60	0.12/0.11	18/15	B	2260/2500	44/50	0.11/0.12	39/43	1800v/min
IB-A11025HSL(T)	220/240	50/60	0.10/0.08	18/15	S	2160/2400	42/48	0.10/0.11	38/41	1800v/min
IB-A11025HBL(T)	220/240	50/60	0.10/0.08	18/15	B	2260/2500	44/50	0.11/0.12	39/43	1800v/min
IB-A11025HSL(T)	380	50/60	0.06/0.04	18/15	S	2160/2400	42/48	0.10/0.11	38/41	1800v/min
IB-A11025HBL(T)	380	50/60	0.06/0.04	18/15	B	2260/2500	44/50	0.11/0.12	39/43	1800v/min

AC 系列 IB-A12025



120x120x25mm

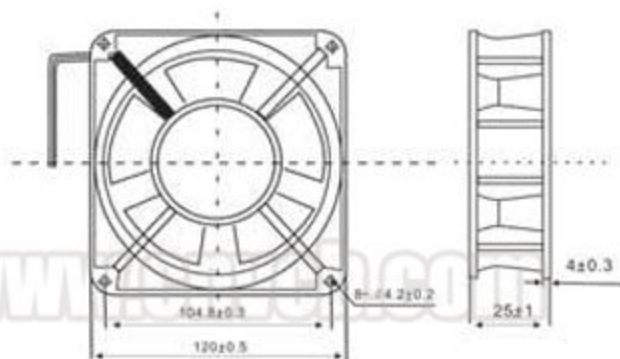

型号	电压	频率	电流	功率	轴承	转速	风量	风压	噪声	耐压
Model	Volt (VAC)	Frequency Hz	Current (AMP)	Power	Bearing system:x	Speed (RPM)	Air Flow (CFM)	Static Pressure	Noise (dBA)	Resist strength
IB-A12025HSL(T)	110/120	50/60	0.12/0.11	19/16	S	2200/2600	45/60	0.11/0.12	38/42	1800v/min
IB-A12025HBL(T)	110/120	50/60	0.12/0.11	19/16	B	2300/2700	47/62	0.12/0.13	40/44	1800v/min
IB-A12025HSL(T)	220/240	50/60	0.10/0.08	19/16	S	2200/2600	45/60	0.11/0.12	38/42	1800v/min
IB-A12025HBL(T)	220/240	50/60	0.10/0.08	19/16	B	2300/2700	47/62	0.12/0.13	40/44	1800v/min
IB-A12025HSL(T)	380	50/60	0.06/0.04	19/16	S	2200/2600	45/60	0.11/0.12	38/42	1800v/min
IB-A12025HBL(T)	380	50/60	0.06/0.04	19/16	B	2300/2700	47/62	0.12/0.13	40/44	1800v/min

AC 系列 IB-A12038 (白)



120x120x38mm

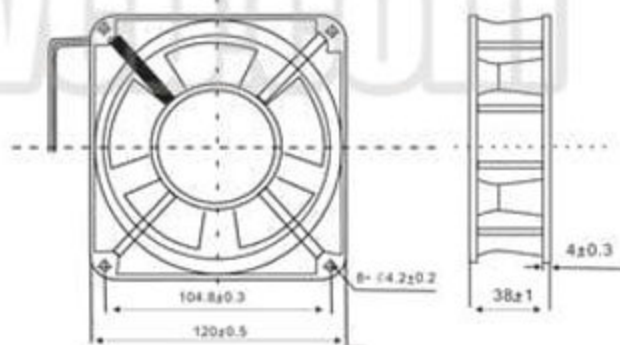

型号	电压	频率	电流	功率	轴承	转速	风量	风压	噪声	耐压
Model	Volt (VAC)	Frequency Hz	Current (AMP)	Power	Bearing system:x	Speed (RPM)	Air Flow (CFM)	Static Pressure	Noise (dBA)	Resist strength
IB-A12038HSL(T)	110/120	50/60	0.21/0.18	21/19	S	2500/2900	80/90	0.25/0.30	44/48	1800v/min
IB-A12038HBL(T)	110/120	50/60	0.21/0.18	21/19	B	2600/3000	85/100	0.26/0.31	46/50	1800v/min
IB-A12038HSL(T)	220/240	50/60	0.13/0.11	21/19	S	2500/2900	80/90	0.25/0.30	44/48	1800v/min
IB-A12038HBL(T)	220/240	50/60	0.13/0.11	21/19	B	2600/3000	85/100	0.26/0.31	46/50	1800v/min
IB-A12038HSL(T)	380	50/60	0.08/0.05	21/19	S	2500/2900	80/90	0.25/0.30	44/48	1800v/min
IB-A12038HBL(T)	380	50/60	0.08/0.05	21/19	B	2600/3000	85/100	0.26/0.31	46/50	1800v/min

AC 系列 IB - A12038



120x120x38mm

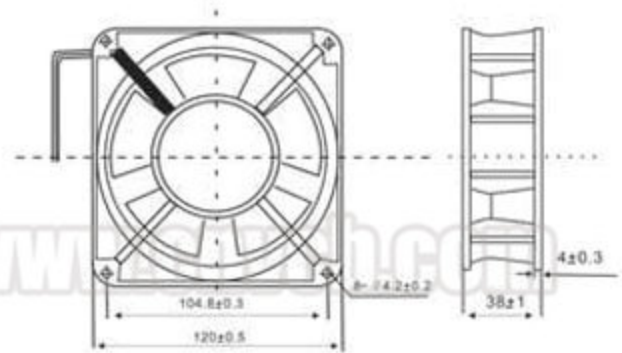

型号	电压	频率	电流	功率	轴承	转速	风量	风压	噪声	耐压
Model	Volt (VAC)	Frequency Hz	Current (AMP)	Power	Bearing system:x	Speed (RPM)	Air Flow (CFM)	Static Pressure	Noise (dBA)	Resist strength
IB-A12038HSL(T)	110/120	50/60	0.21/0.18	21/19	S	2500/2900	80/90	0.25/0.30	44/48	1800v/min
IB-A12038HBL(T)	110/120	50/60	0.21/0.18	21/19	B	2600/3000	85/100	0.26/0.31	46/50	1800v/min
IB-A12038HSL(T)	220/240	50/60	0.13/0.11	21/19	S	2500/2900	80/90	0.25/0.30	44/48	1800v/min
IB-A12038HBL(T)	220/240	50/60	0.13/0.11	21/19	B	2600/3000	85/100	0.26/0.31	46/50	1800v/min
IB-A12038HSL(T)	380	50/60	0.08/0.05	21/19	S	2500/2900	80/90	0.25/0.30	44/48	1800v/min
IB-A12038HBL(T)	380	50/60	0.08/0.05	21/19	B	2600/3000	85/100	0.26/0.31	46/50	1800v/min

AC 系列 IB - A12038 七叶



120x120x38mm

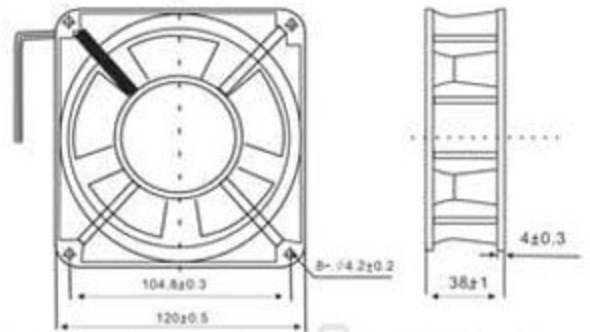

型号	电压	频率	电流	功率	轴承	转速	风量	风压	噪声	耐压
Model	Volt (VAC)	Frequency Hz	Current (AMP)	Power	Bearing system:x	Speed (RPM)	Air Flow (CFM)	Static Pressure	Noise (dBA)	Resist strength
IB-A12038HSL(T)	110/120	50/60	0.21/0.18	21/19	S	2400/2800	90/115	0.25/0.30	44/48	1800v/min
IB-A12038HBL(T)	110/120	50/60	0.21/0.18	21/19	B	2500/2900	100/120	0.26/0.31	46/50	1800v/min
IB-A12038HSL(T)	220/240	50/60	0.13/0.11	21/19	S	2400/2800	90/115	0.25/0.30	44/48	1800v/min
IB-A12038HBL(T)	220/240	50/60	0.13/0.11	21/19	B	2500/2900	100/120	0.26/0.31	46/50	1800v/min
IB-A12038HSL(T)	380	50/60	0.08/0.05	21/19	S	2400/2800	90/115	0.25/0.30	44/48	1800v/min
IB-A12038HBL(T)	380	50/60	0.08/0.05	21/19	B	2500/2900	100/120	0.26/0.31	46/50	1800v/min

AC 系列 IB-A13538



135x135x38mm

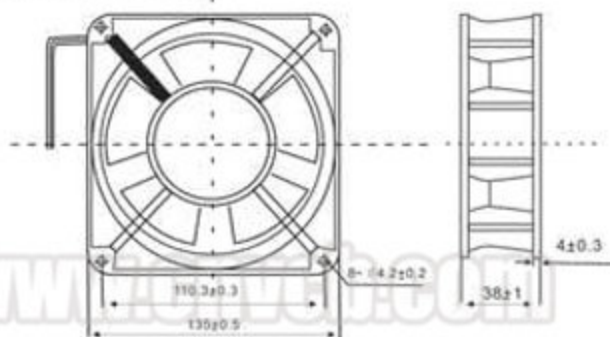

型号	电压	频率	电流	功率	轴承	转速	风量	风压	噪声	耐压
Model	Volt (VAC)	Frequency Hz	Current (AMP)	Power	Bearing system:x	Speed (RPM)	Air Flow (CFM)	Static Pressure	Noise (dBA)	Resist strength
IB-A13538HSL	110/120	50/60	0.30/0.28	25	S	2400/2700	90/102	0.25/0.30	51/53	1800v/min
IB-A13538HBL	110/120	50/60	0.30/0.28	25	B	2500/2800	90/102	0.26/0.31	51/53	1800v/min
IB-A13538HSL	220/240	50/60	0.15/0.14	24	S	2400/2700	90/102	0.25/0.30	51/53	1800v/min
IB-A13538HBL	220/240	50/60	0.15/0.14	24	B	2500/2800	90/102	0.26/0.31	51/53	1800v/min

AC 系列 IB-A15050



150x150x50mm

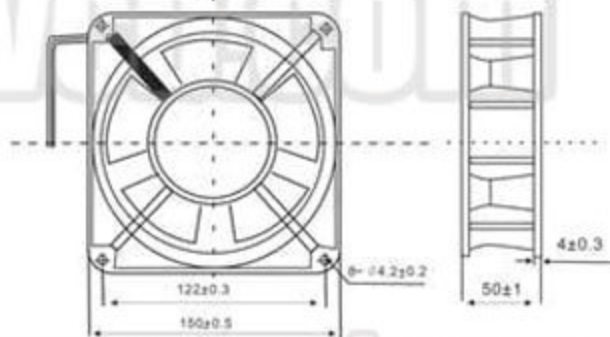

型号	电压	频率	电流	功率	轴承	转速	风量	风压	噪声	耐压
Model	Volt (VAC)	Frequency Hz	Current (AMP)	Power	Bearing system:x	Speed (RPM)	Air Flow (CFM)	Static Pressure	Noise (dBA)	Resist strength
IB-A15050HSL(T)	110/120	50/60	0.45/0.40	38/35	S	2500/2900	145/175	0.45/0.46	55/60	1800v/min
IB-A15050HBL(T)	110/120	50/60	0.45/0.40	38/35	B	2600/3000	150/180	0.47/0.48	57/62	1800v/min
IB-A15050HSL(T)	220/240	50/60	0.21/0.20	38/35	S	2500/2900	145/175	0.35/0.42	55/60	1800v/min
IB-A15050HBL(T)	220/240	50/60	0.21/0.20	38/35	B	2600/3000	150/180	0.38/0.44	57/62	1800v/min
IB-A15050HSL(T)	380	50/60	0.11/0.10	38/35	S	2500/2900	145/175	0.35/0.42	55/60	1800v/min
IB-A15050HBL(T)	380	50/60	0.11/0.10	38/35	B	2600/3000	150/180	0.38/0.44	57/62	1800v/min

AC 系列 IB-A15050 (白)



170x51mm

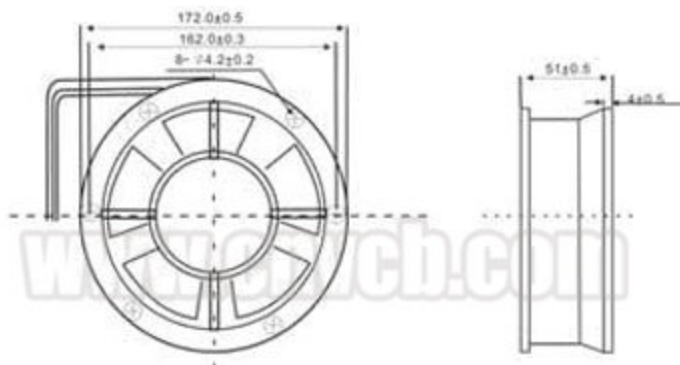

型号	电压	频率	电流	功率	轴承	转速	风量	风压	噪声	耐压
Model	Volt (VAC)	Frequency Hz	Current (AMP)	Power	Bearing system:x	Speed (RPM)	Air Flow (CFM)	Static Pressure	Noise (dBA)	Resist strength
IB-A15050HSL(T)	110/120	50/60	0.45/0.40	38/35	S	2500/2900	145/175	0.45/0.46	55/60	1800v/min
IB-A15050HBL(T)	110/120	50/60	0.45/0.40	38/35	B	2600/3000	150/180	0.47/0.48	57/62	1800v/min
IB-A15050HSL(T)	220/240	50/60	0.21/0.20	38/35	S	2500/2900	145/175	0.35/0.42	55/60	1800v/min
IB-A15050HBL(T)	220/240	50/60	0.21/0.20	38/35	B	2600/3000	150/180	0.38/0.44	57/62	1800v/min
IB-A15050HSL(T)	380	50/60	0.11/0.10	38/35	S	2500/2900	145/175	0.35/0.42	55/60	1800v/min
IB-A15050HBL(T)	380	50/60	0.11/0.10	38/35	B	2600/3000	150/180	0.38/0.44	57/62	1800v/min

AC 系列 IB-A15050



170x51mm

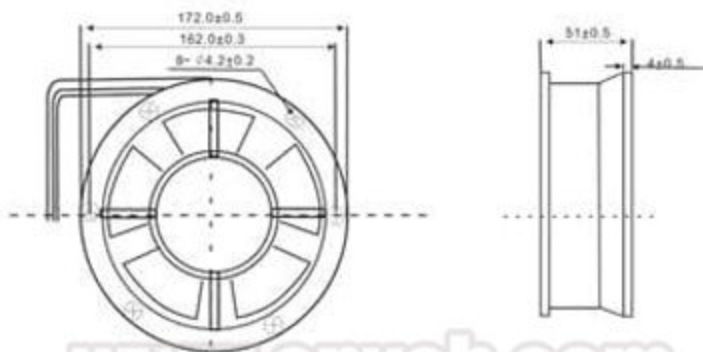

型号	电压	频率	电流	功率	轴承	转速	风量	风压	噪声	耐压
Model	Volt (VAC)	Frequency Hz	Current (AMP)	Power	Bearing system:x	Speed (RPM)	Air Flow (CFM)	Static Pressure	Noise (dBA)	Resist strength
IB-A15050HSL(T)	110/120	50/60	0.45/0.40	38/35	S	2500/2900	145/175	0.45/0.46	55/60	1800v/min
IB-A15050HBL(T)	110/120	50/60	0.45/0.40	38/35	B	2600/3000	150/180	0.47/0.48	57/62	1800v/min
IB-A15050HSL(T)	220/240	50/60	0.21/0.20	38/35	S	2500/2900	145/175	0.35/0.42	55/60	1800v/min
IB-A15050HBL(T)	220/240	50/60	0.21/0.20	38/35	B	2600/3000	150/180	0.38/0.44	57/62	1800v/min
IB-A15050HSL(T)	380	50/60	0.11/0.10	38/35	S	2500/2900	145/175	0.35/0.42	55/60	1800v/min
IB-A15050HBL(T)	380	50/60	0.11/0.10	38/35	B	2600/3000	150/180	0.38/0.44	57/62	1800v/min

AC 系列 IB-A16855



172x55mm

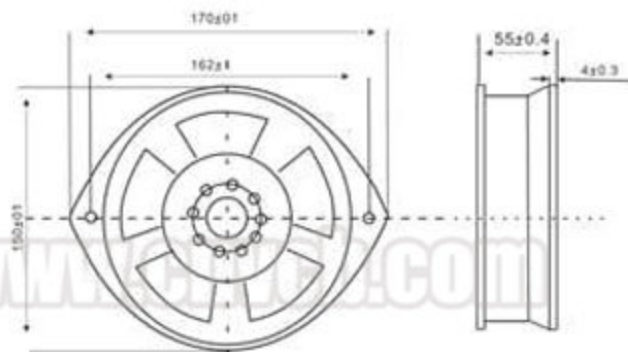

型号	电压	频率	电流	功率	轴承	转速	风量	风压	噪声	耐压
Model	Volt (VAC)	Frequency Hz	Current (AMP)	Power	Bearing system:x	Speed (RPM)	Air Flow (CFM)	Static Pressure	Noise (dBA)	Resist strength
IB-A16855HBL	110/120	50/60	0.30/0.28	48/46	B	2750/3100	160/192	0.40/0.46	50/53	1800v/min
IB-A16855HBL	220/240	50/60	0.15/0.14	48/46	B	2750/3100	160/192	0.40/0.46	50/53	1800v/min

AC 系列 IB-A17238



172x150x38mm

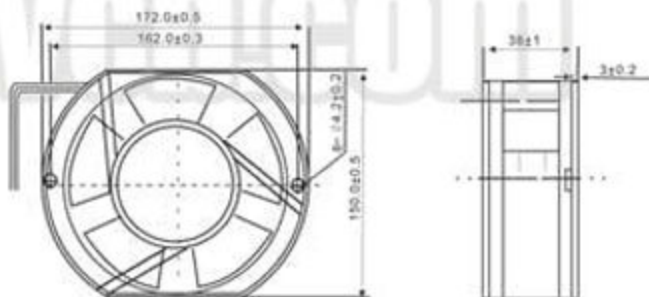

型号	电压	频率	电流	功率	轴承	转速	风量	风压	噪声	耐压
Model	Volt (VAC)	Frequency Hz	Current (AMP)	Power	Bearing system:x	Speed (RPM)	Air Flow (CFM)	Static Pressure	Noise (dBA)	Resist strength
IB-A17238HBL	110/120	50	2.1	30	B	2400	155	0.40	55	1800v/min
IB-A17238HBL	220/240	50	2.1	30	B	2400	155	0.40	55	1800v/min

AC 系列 IB-A17251



172x150x50mm

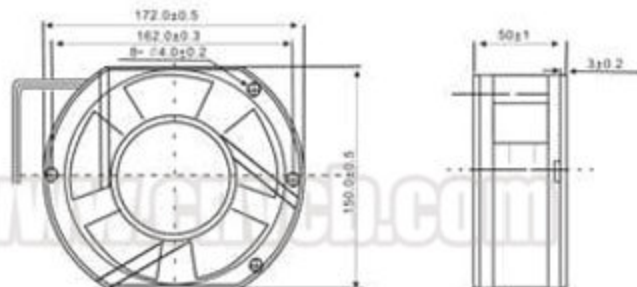

型号	电压	频率	电流	功率	轴承	转速	风量	风压	噪声	耐压
Model	Volt (VAC)	Frequency Hz	Current (AMP)	Power	Bearing system:x	Speed (RPM)	Air Flow (CFM)	Static Pressure	Noise (dBA)	Resist strength
IB-A15050HSL(T)	110/120	50/60	0.45/0.40	38/35	S	2500/2900	145/175	0.45/0.46	55/60	1800v/min
IB-A15050HBL(T)	110/120	50/60	0.45/0.40	38/35	B	2600/3000	150/180	0.47/0.48	57/62	1800v/min
IB-A15050HSL(T)	220/240	50/60	0.21/0.20	38/35	S	2500/2900	145/175	0.35/0.42	55/60	1800v/min
IB-A15050HBL(T)	220/240	50/60	0.21/0.20	38/35	B	2600/3000	150/180	0.38/0.44	57/62	1800v/min
IB-A15050HSL(T)	380	50/60	0.11/0.10	38/35	S	2500/2900	145/175	0.35/0.42	55/60	1800v/min
IB-A15050HBL(T)	380	50/60	0.11/0.10	38/35	B	2600/3000	150/180	0.38/0.44	57/62	1800v/min

AC 系列 IB-A17251 七叶



172x150x50mm

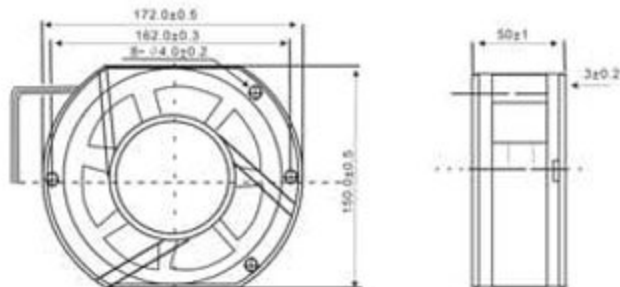

型号	电压	频率	电流	功率	轴承	转速	风量	风压	噪声	耐压
Model	Volt (VAC)	Frequency Hz	Current (AMP)	Power	Bearing system:x	Speed (RPM)	Air Flow (CFM)	Static Pressure	Noise (dBA)	Resist strength
IB-A15050HSL(T)	110/120	50/60	0.45/0.40	38/35	S	2500/2900	185/205	0.45/0.46	55/60	1800v/min
IB-A15050HBL(T)	110/120	50/60	0.45/0.40	38/35	B	2600/3000	190/210	0.47/0.48	57/62	1800v/min
IB-A15050HSL(T)	220/240	50/60	0.21/0.20	38/35	S	2500/2900	185/205	0.35/0.42	55/60	1800v/min
IB-A15050HBL(T)	220/240	50/60	0.21/0.20	38/35	B	2600/3000	190/210	0.38/0.44	57/62	1800v/min
IB-A15050HSL(T)	380	50/60	0.11/0.10	38/35	S	2500/2900	185/205	0.35/0.42	55/60	1800v/min
IB-A15050HBL(T)	380	50/60	0.11/0.10	38/35	B	2600/3000	190/210	0.38/0.44	57/62	1800v/min

AC 系列 IB-A18060



180x180x60mm

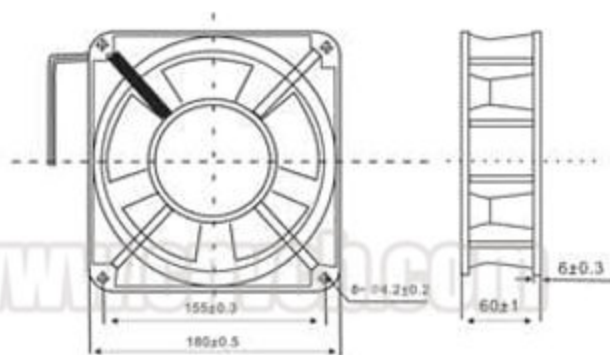

型号	电压	频率	电流	功率	轴承	转速	风量	风压	噪声	耐压
Model	Volt (VAC)	Frequency Hz	Current (AMP)	Power	Bearing system:x	Speed (RPM)	Air Flow (CFM)	Static Pressure	Noise (dBA)	Resist strength
IB-A18060HBL(T)	110/120	50/60	0.53/0.50	55/50	B	2500/3000	380/420	0.79/1.02	58/62	1800v/min
IB-A18060HBL(T)	220/240	50/60	0.23/0.24	55/50	B	2500/3000	380/420	0.79/1.02	58/62	1800v/min
IB-A18060HBL(T)	380	50/60	0.18/0.16	55/50	B	2500/3000	380/420	0.79/1.02	58/62	1800v/min

AC 系列 IB-A20060-Y



220x60mm

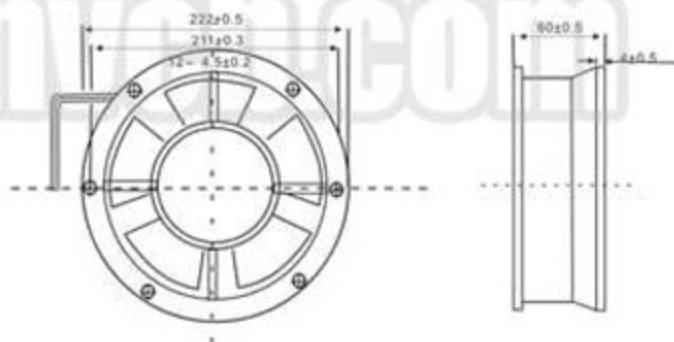

型号	电压	频率	电流	功率	轴承	转速	风量	风压	噪声	耐压
Model	Volt (VAC)	Frequency Hz	Current (AMP)	Power	Bearing system:x	Speed (RPM)	Air Flow (CFM)	Static Pressure	Noise (dBA)	Resist strength
IB-A20060HBL(T)	110/120	50/60	0.60/0.55	55/50	B	2500/3000	400/450	0.52/0.54	58/62	1800v/min
IB-A20060HBL(T)	220/240	50/60	0.40/0.36	55/50	B	2500/3000	400/450	0.52/0.54	58/62	1800v/min
IB-A20060HBL(T)	380	50/60	0.20/0.15	55/50	B	2500/3000	400/450	0.52/0.54	58/62	1800v/min

AC 系列 IB-A20060



200x200x60mm

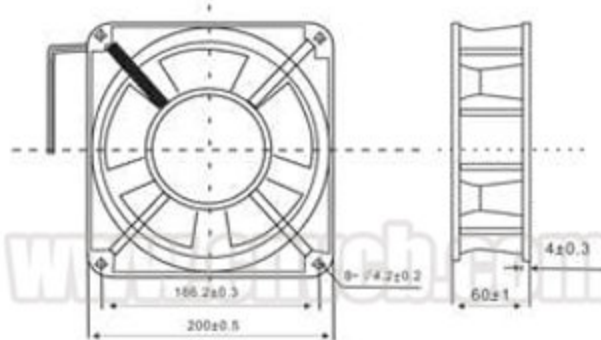

型号	电压	频率	电流	功率	轴承	转速	风量	风压	噪声	耐压
Model	Volt (VAC)	Frequency Hz	Current (AMP)	Power	Bearing system:x	Speed (RPM)	Air Flow (CFM)	Static Pressure	Noise (dBA)	Resist strength
IB-A20060HBL(T)	110/120	50/60	0.60/0.55	55/50	B	2500/3000	380/420	0.52/0.54	58/62	1800v/min
IB-A20060HBL(T)	220/240	50/60	0.40/0.36	55/50	B	2500/3000	380/420	0.52/0.54	58/62	1800v/min
IB-A20060HBL(T)	380	50/60	0.20/0.15	55/50	B	2500/3000	380/420	0.52/0.54	58/62	1800v/min

AC 系列 IB-A25489 - Y



254x89mm

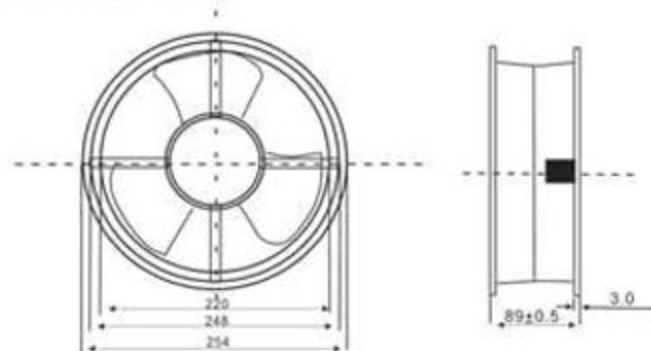

型号	电压	频率	电流	功率	轴承	转速	风量	风压	噪声	耐压
Model	Volt (VAC)	Frequency Hz	Current (AMP)	Power	Bearing system:x	Speed (RPM)	Air Flow (CFM)	Static Pressure	Noise (dBA)	Resist strength
IB-A25489HBL(T)	110/120	50/60	0.60/0.55	55/50	B	2500/3000	400/450	0.52/0.54	58/62	1800v/min
IB-A25489HBL(T)	220/240	50/60	0.40/0.36	55/50	B	2500/3000	400/450	0.52/0.54	58/62	1800v/min
IB-A25489HBL(T)	380	50/60	0.20/0.15	55/50	B	2500/3000	400/450	0.52/0.54	58/62	1800v/min